



FITTING INSTRUCTIONS

Part Number: 5448140

Product Description: UNDER VEHICLE PROTECTION

Suited to vehicle/s: HOLDEN COLORADO 9/16 ON AUTO ONLY

Please place these instructions in vehicle glove box when complete.

WARNING

REGARDING VEHICLES EQUIPPED WITH SRS AIRBAG:

When installed in accordance with these instructions, the vehicle protection panels do not affect operation of the SRS airbag.

ALSO, NOTE THE FOLLOWING:

- ◆ This product must be installed exactly as per these instructions using only the hardware supplied.
- ◆ Do not use this product for any vehicle make or model, other than those specified by ARB.
- ◆ Do not remove labels (if any) from this product.
- ◆ This product or its fixing must not be modified in any way.
- ◆ The installation of this product may require the use of specialized tools and/or techniques
- ◆ These instructions are correct as at the publication date. ARB Corporation Ltd. cannot be held responsible for the impact of any changes subsequently made by the vehicle manufacturer
- ◆ During installation, it is the duty of the installer to check correct operation/clearances of all components
- ◆ Work safely at all times
- ◆ Unless otherwise instructed, tighten fasteners to specified torque

◆ **IMPORTANT: Routinely inspect and ensure that there is NO trapped material between the Diesel Particulate Filters (DPF's) and the Covers**

ARB 4x4 ACCESSORIES

Corporate Head Office

42-44 Garden St
Kilsyth, Victoria
AUSTRALIA 3137

Tel: +61 (3) 9761 6622
Fax: +61 (3) 9761 6807

Australian enquiries
North & South American enquiries
Other international enquiries

sales@arb.com.au
sales@arbusa.com
exports@arb.com.au

www.arb.com.au

IMPORTANT INFORMATION. GENERAL CARE AND MAINTENANCE

By choosing ARB vehicle protection, you have bought a product that is one of the most sought after 4WD products in the world. Your under vehicle protection panels are a properly engineered, reliable, quality accessory that represents excellent value.



- While these panels have been engineered for strength and functionality care and good judgment should be taken when traversing difficult off-road conditions to minimise damage to panels and vehicle.
- During servicing when panels are removed ensure fasteners are re-fitted to the correct torque values.
- Visually inspect the panels and Diesel Particulate Filter (DPF) cover on a regular basis. Dirt and foreign matter must be washed out to minimise build-up around hot components, especially around the Diesel Particulate Filters. BE VERY CAREFUL when removing foreign matter with hands while vehicle is hot or running. Replace any components as necessary. This service can be performed by your local authorized ARB Stockist.

FITTING REQUIREMENTS

REQUIRED TOOLS FOR FITMENT OF PRODUCT:

BASIC TOOL KIT	HOIST
TORQUE WRENCH (9 – 52Nm)	

HAVE AVAILABLE THESE SAFETY ITEMS WHEN FITTING PRODUCT:

Protective eyewear		Hearing protection	
---------------------------	---	---------------------------	---

NOTE: ‘WARNING’ notes in the fitting procedure relate to OHS situations, where to avoid a potentially hazardous situation it is suggested that protective safety gear be worn or a safe work procedure be employed. If these notes and warnings are not heeded, injury may result.

FASTENER TORQUE SETTINGS:

SIZE	Torque Nm	Torque lbft	
M6	9	7	
M8	22	16	
M10x1.5	44	32	
M10x1.25	52	57	

PARTS LISTING			
APPLICATION.	PART NO.	QTY.	DESCRIPTION.
FIT FRONT PANEL TO CHASSIS	6523151	1	PANEL ASSY FRONT
	6151769	4	BOLT FLANGE M10x1.25x30 PC8.8 TZP480
	4584366	4	WASHER FLAT M10x30x4 HT TZP480
	(NOT SUPPLIED)	3	M8x1.25x25 BOLTS (C/W BULLBAR)
	(NOT SUPPLIED)	3	M6x1x25 SEMS SCREWS (OE)
FIT DIFF PANEL TO FRONT PANEL AND CHASSIS	6523153	1	PANEL ASSY DIFF
	6151022	3	BOLT M8x1.25x25 PC8.8 TZP
	4584311	3	WASHER FLAT M8x18x2 HT TZP
	6151769	2	BOLT FLANGE M10x1.25x30 PC8.8 TZP480
	4584366	2	WASHER FLAT M10x30x4 HT TZP480
FIT TRANSMISSION PANEL TO DIFF PANEL AND CHASSIS	6523155	1	PANEL ASSY TRANSMISSION
	6151022	3	BOLT M8 X 25
	4584311	3	WASHER FLAT M8x18x2 HT TZP
	6151542	2	SCREW SEMS M10x1.5x40 PC8.8 TZP
	4654084	2	NUT PLATE M10x1.5 TZP
FIT TRANSFER CASE PANEL TO TRANSMISSION PANEL AND CHASSIS	6521357	1	PANEL ASSY TRANSFER CASE
	6151022	3	BOLT M8x1.25x25 PC8.8 TZP
	4584366	2	WASHER FLAT M8x18x2 HT TZP
	6151083	2	BOLT M8x1.25x35 PC8.8 TZP480
	4654145	2	NUT PLATE M8x1.25 TZP
	6151542	2	SCREW SEMS M10x1.5x40 PC8.8 TZP
	4654084	2	NUT PLATE M10x1.5 TZP

FITTING PROCEDURE

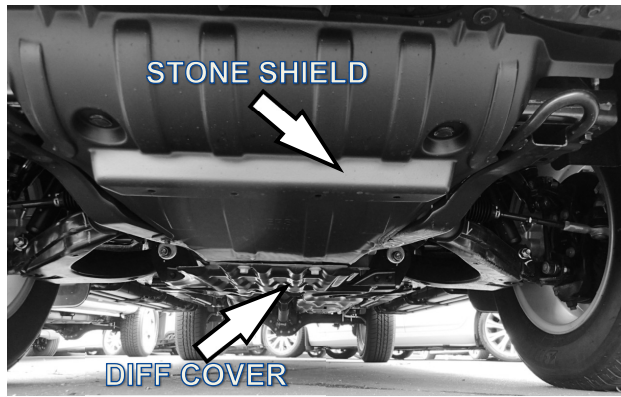

1. Remove original stone shield and diff covers from vehicle. Discard covers and fasteners.

NOTE: If vehicle is fitted with an ARB bullbar retain the three front M8 bolts joining the O.E panel to bullbar stone shield.

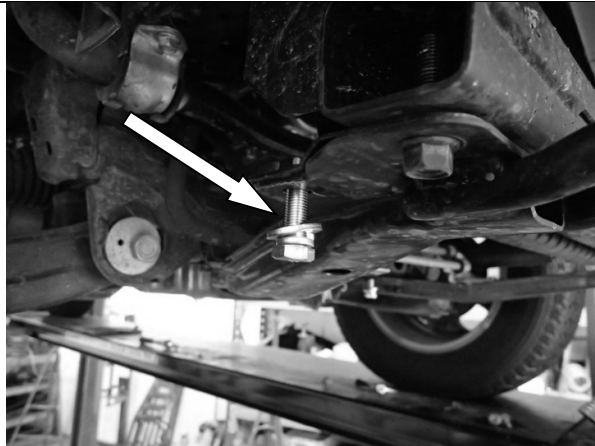
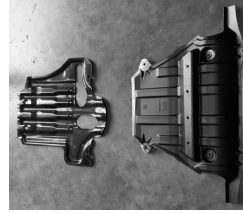

2. If fitted, remove original tow hook bolt. Repeat for other side.

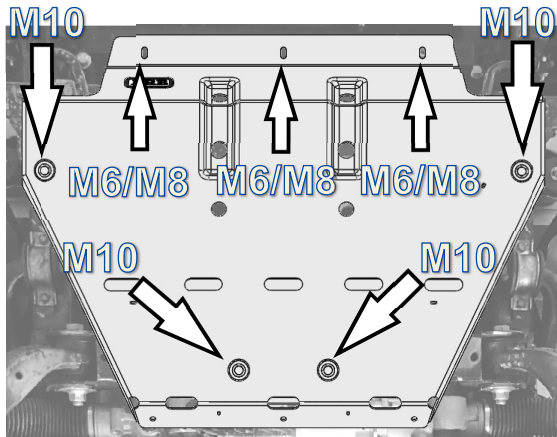

3. Fit Front Panel as shown. **Loosely secure** front LH and RH sides of panel and rear of panel to chassis with four M10x1.25x30 hex flange screws and washers.

NOTE:

- A) If fitted with bullbar re-use 3x M8 fasteners for front of UVP that were removed in step 1.
- B) If fitted with O/E Bumper re-use 3x M6x25 SEMS screws to loosely secure slots at the front of the panel

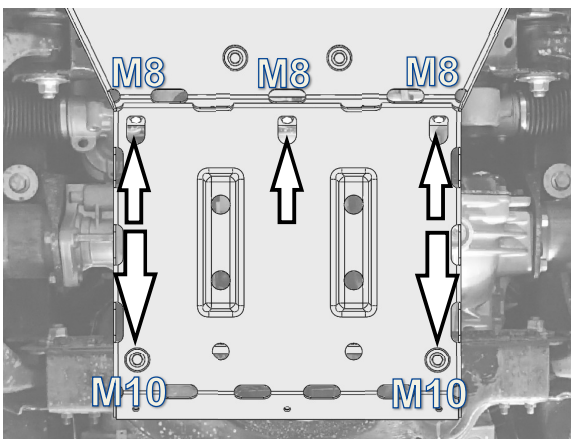

4. Fit Diff Panel as shown. **Loosely secure** front of panel to rear of Front Panel using M8 hardware. **Loosely secure** rear of panel to chassis using two M10x1.25x30 hex flange screws and washers.

FITTING PROCEDURE

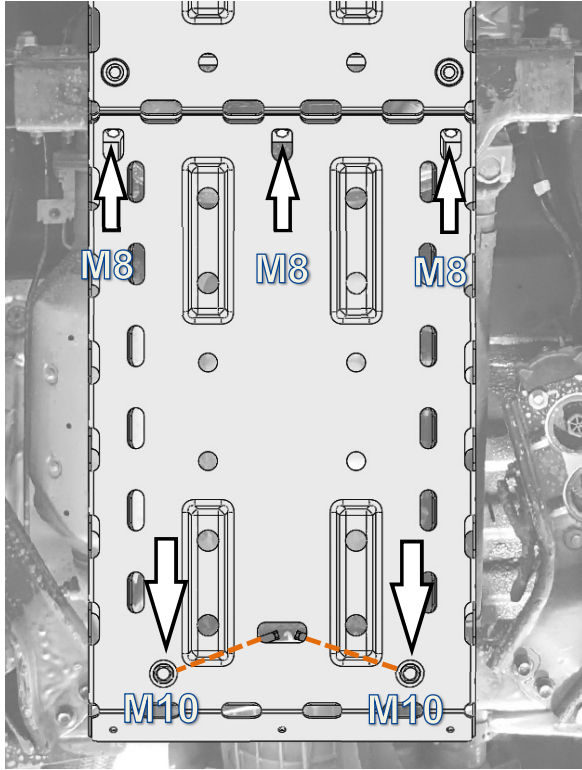

5. Fit Transmission Panel as shown. **Loosely secure** front of panel to rear of Diff Panel using M8 hardware. **Loosely secure** rear of panel to chassis using two SEM screws M10x1.5x40 and two Nut Plates M10x1.5

6. **M10 Nut Plate preparation**; bend two M10 Nut Plates as shown below;

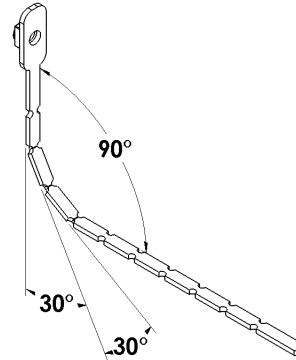

HINT: Feed the M10 Nut Plates through the hole in the panel and up inside the recess in the chassis cross member. Trim off excess stick ends and push up inside the panel so as not to rattle as shown below.

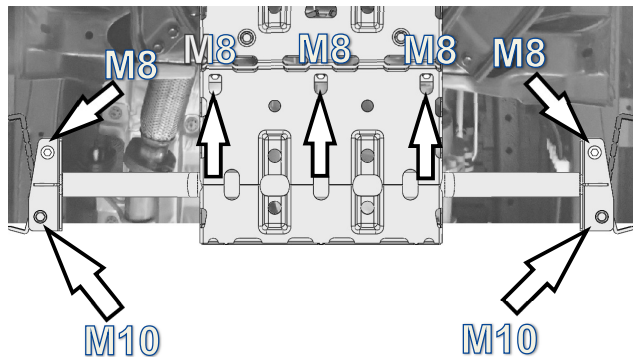
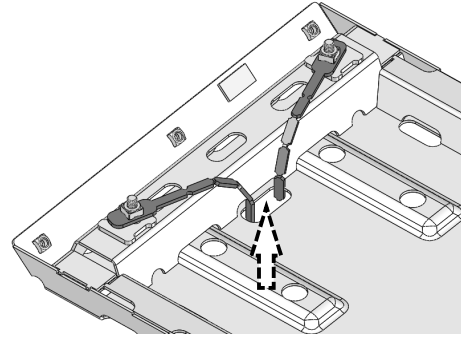

7. Fit the Transfer Case Panel as shown. **Loosely secure** front of panel to rear of Transmission Panel using M8 hardware. **Loosely secure** the two brackets at the sides of the panel to the chassis using two SEM screws M10x1.5x40 into two Nut Plates M10x1.5 (inserted through chassis opening at sides) and two M8x1.25x25 screws into two Nut Plates M8x1.25

8. **M10 Nut Plate preparation**; bend the RH M10 Nut Plate as shown below (LH Opposite);

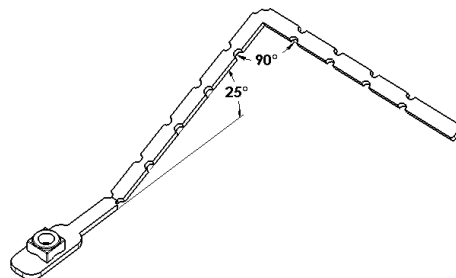

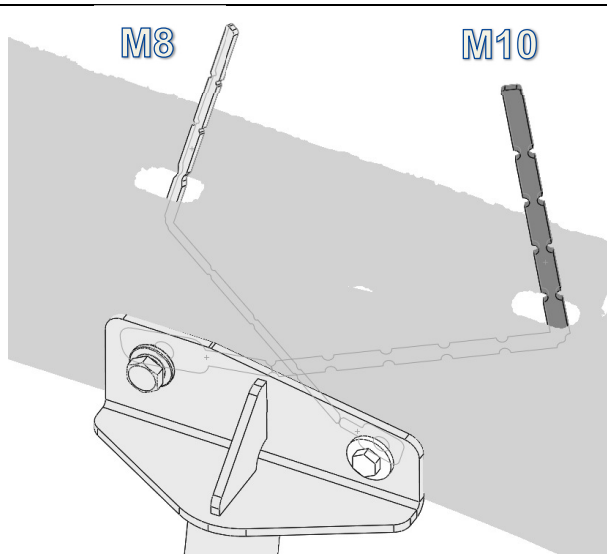

RH SHOWN (LH OPPOSITE)

9. **M8 Nut Plate preparation**; bend the RH M8 Nut Plate as shown below (LH Opposite);

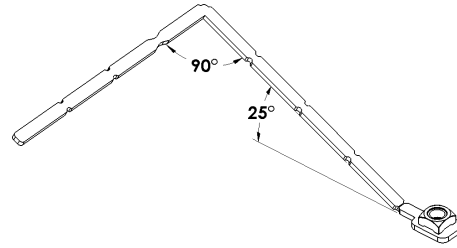

HINT: Feed the Nut Plates through the outboard slots in the chassis to aid assembly.

Trim off excess stick ends and push inside the chassis so as not to rattle.

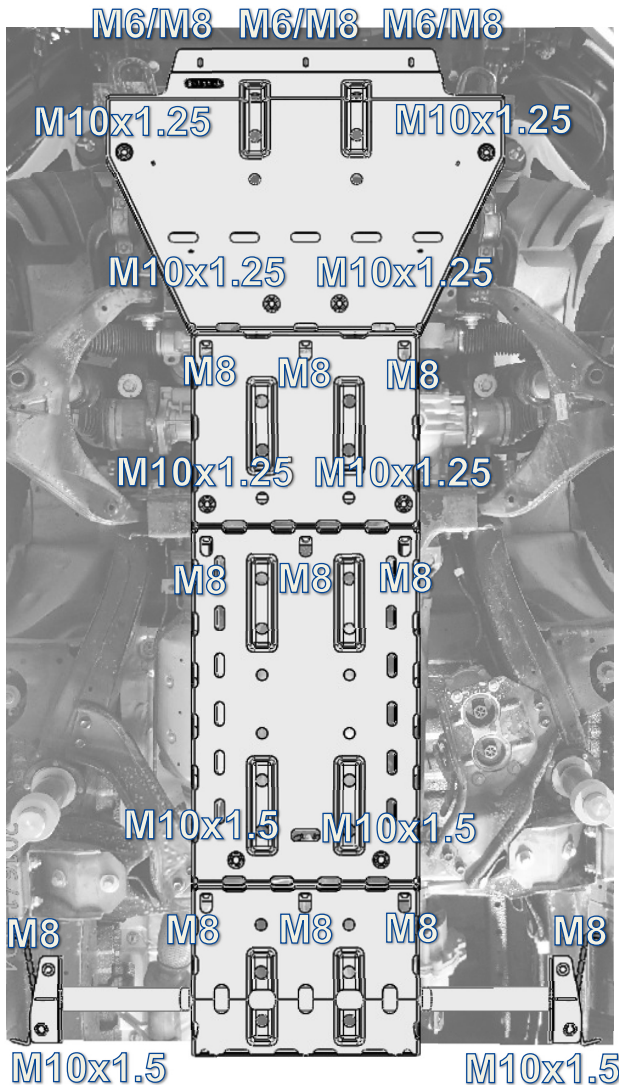

10. Align and centre all of the panels then tighten all fasteners to the torque settings listed below;



M6-9Nm.



M8-22Nm.



M10x1.5-44Nm.



M10x1.25-52Nm.

FITTED PRODUCT

(NOTE: LEFT & RIGHT RECOVERY POINTS ALSO FITTED IN THIS PICTURE)

